

## 6.38 E, Serie A / 6.38 E, Series A

### Ausstattung Elektromäher / Specification - Electric Mowers

Typ / Kurzbez. / short code	6.38 E
Ausführung für / version	International
Geräte - Nr. / part No.	4950080
Schnittbreite / cutting width	38 cm
Chassismaterial / chassis material	Kunststoff / high quality polymer
Gewicht / weight	25 kg
Schalleistung / sound level	94 dB (A)
Ø Rad vorne / front wheel diameter	17 cm (Kugellager / ball bearing)
Ø Rad hinten / rear wheel diameter	20 cm (Kugellager / ball bearing)
Schnitthöhe (cm) / cutting height range	2,5 - 7,2 cm (zentral einstellbar / central adjustable)
Antrieb ja/nein / power drive yes/no	nein / no
Motor - Hersteller / motor producer	Stahlschmidt
Artikel-Nr. Motor / motor part no.	1141080
Leistung / power	1,4 kW
Bremse / blade brake	elektro-mech. / eletromechanical
Kabelführung / cable guide	"Flick-Flack"
Schalter / switch	Bügelschalter / bail arm switch
Griffgestänge / handlebar	Klappgriff, höhenverstellbar / folding handlebar, height adjustable
Fangkorb / grass box	Art.-Nr. / part no.: 4950065 mit Füllstandsanzeige / with grass box fill indicator (56 L)
<u>Drehmomente Chassis / torque settings, chassis fasteners:</u>	
Stützschaale vorne, hinten / support shell front, rear	2 Nm
Lüfter an Motorwelle / fan to motor shaft	22-26 Nm
Messer an Lüfter / blade to fan	22-26 Nm
Motor in Chassis / motor to chassis	4-5 Nm
Griff Motorabdeckung / handle motor cover	2-3 Nm
Führung an Chassis / guide to chassis	4-5 Nm
Fangkorbhälften / grass box half	2-3 Nm
Griffhalter links, rechts / handle fixing left, right	4-5 Nm

**Achtung:** Instandsetzungen an Elektrogeräten dürfen nur von entsprechenden Fachkräften durchgeführt werden !  
Die Isolationswiderstandsmessung / Schutzleiterprüfung gemäß DIN/VDE 0701 Teil 2 ist **nach jeder Reparatur** vorzunehmen.

**Attention:** Repairs on electrical appliances must only be carried out by qualified specialists !  
The verification of the insulating resistance / protective conductor examination according to DIN/VDE 0701 part 2 **must be carried out after each repair !**

Ⓓ 6.38 E 4950 080, Serie A, Chassis

ⒼⒷ 6.38 E 4950 080, Series A, Chassis

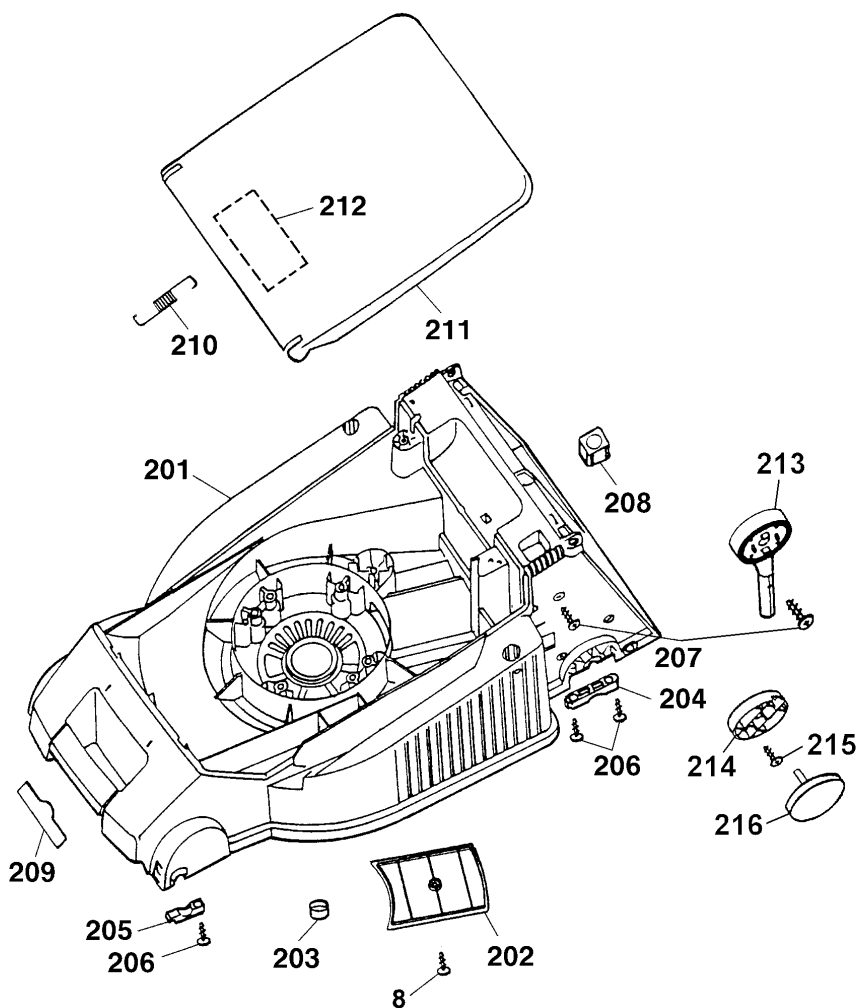

## 6.38 E Chassis

Bild-Nr. / Ref. No.	Best.-Nr. / Part No.	Bezeichnung	Description
201	4961 300	Chassis	chassis
202	4961 324	Keilriemenabdeckung	v-belt cover
203	4961 305	Verschlussstopfen	plug
204	4961 313	Stützschale, hinten (2 St.)	rear support shell (2 piec.)
205	4961 312	Stützschale, vorne (2 St.)	front support shell (2 piec.)
206	0012 631	Schraube (7 Stück)	screw (7 pieces)
207	0010 931	SF-Schraube (9 Stück)	screw (4 pieces)
208	4961 304	Knopf	button
209	0051 115	WOLF-Garten Marke	"WOLF-Garten" brand
210	4961 108	Zugfeder	tension spring
211	4628 302	Schutzklappe (rot)	rear flap (red)
212	0051 244	Sicherheitsetikett	safety label
213	4950 030	Griffhalter (2 Stück)	handlebar holder (2 piec.)
214	4950 126	Verstellring (2 Stück)	adjusting ring (2 pieces)
215	0010 933	SF-Schraube (4 Stück)	screw (4 pieces)
216	4950 010	Handrad (2 Stück)	handwheel (2 pieces)

Ⓓ 6.38 E 4950 080, Serie A, Achse, Räder,  
Höhenverstellung

ⒼⒷ 6.38 E 4950 080, Series A, Axle, Wheels,  
Height-adjustment

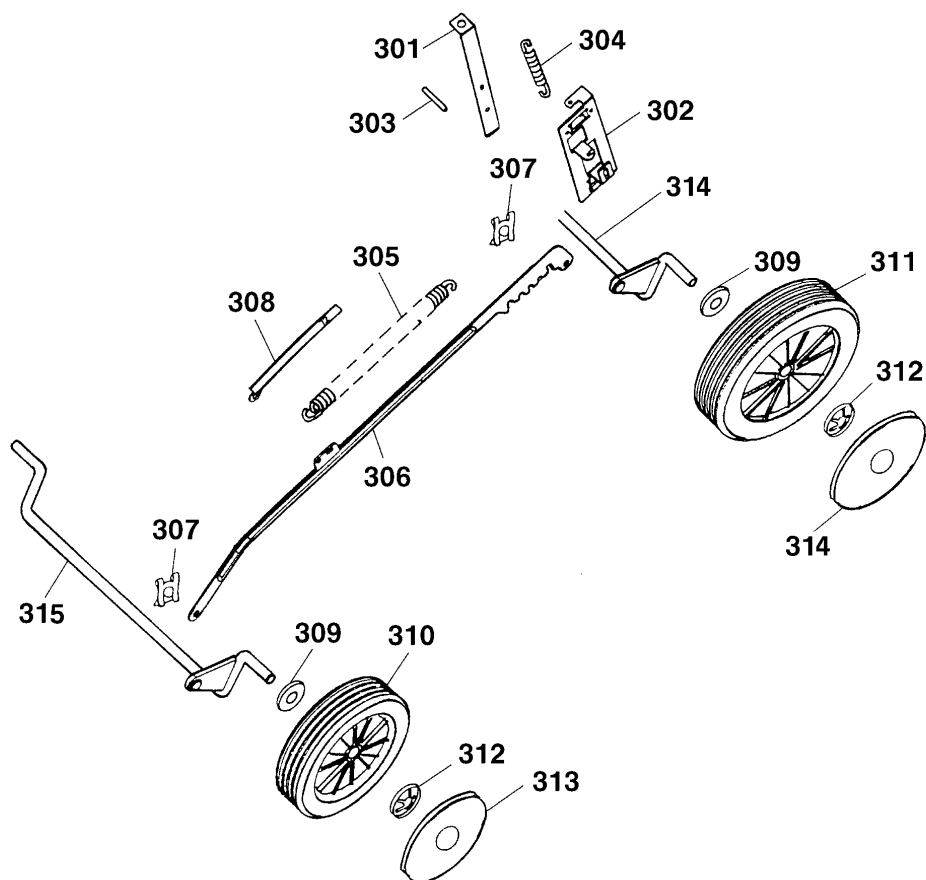

**6.38 E Achse, Räder, Höhenverstellung**  
**6.38 E Axle, Wheels, Height-adjustment**

Bild-Nr. / Ref. No.	Best.-Nr. / Part No.	Bezeichnung	Description
301	4961 512	Rasthebel	lock lever
302	4001 010	Führung	guiding
303	0018 878	Spannstift	dowel pin
304	4961 514	Zugfeder	tension spring
305	4961 107	Zugfeder	tension spring
306	4001 504	Verbindungsstange	connecting rod
307	0020 981	SL-Sicherung (2 Stück)	retaining clip (2 pieces)
308	4961 307	Höhenanzeige	height position indicator
309	0017 112	Scheibe (8 Stück)	washer (8 pieces)
310	6440 050	Rad 170 mm Ø (2 Stück)	wheel 170 mm dia. (2 piec.)
311	6440 051	Rad 200 mm Ø (2 Stück)	wheel 200 mm dia. (2 piec.)
312	0020 700	Schnellbefestiger (4 St.)	quick fixing clip (4 piec.)
313	6450 520	Deckel 170 mm Ø (2 St.)	hub cap 170 mm dia. (2 p.)
314	6450 530	Deckel 200 mm Ø (2 St.)	hub cap 200 mm dia. (2 p.)
315	4961 011	Achse (2 Stück)	axle (2 pieces)

**D** 6.38 E 4950 080, Serie A, Griff, Schalter

**GB** 6.38 E 4950 080, Series A, Handlebar, Switch

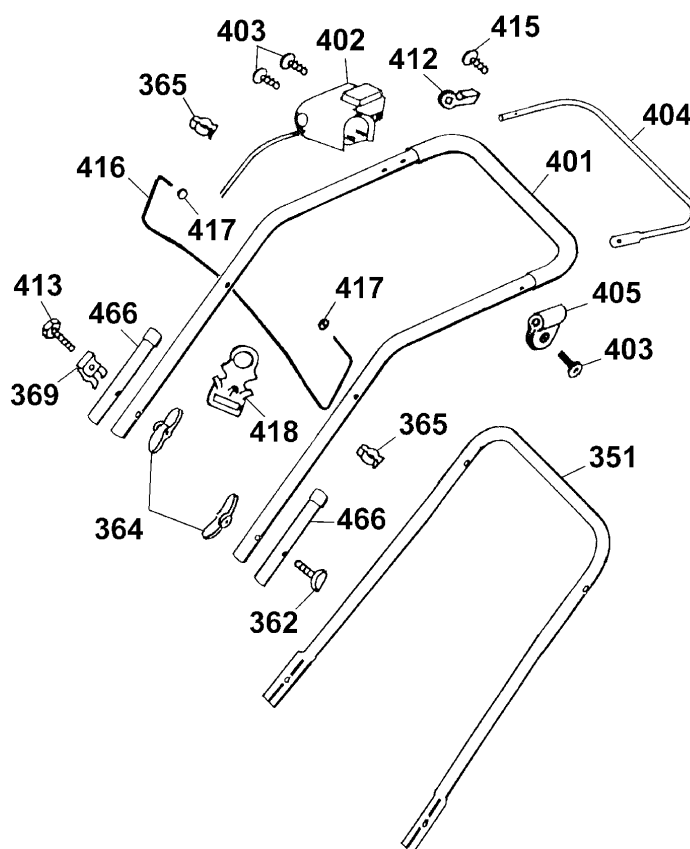

## 6.38 E Griff, Schalter

## 6.38 E Handlebar, Switch

Bild-Nr. / Ref. No.	Best.-Nr. / Part No.	Bezeichnung	Description
351	4011 122	Griffunterteil	lower handlebar
362	4901 101	Verbindungsschraube	binding screw
364	0016 718	Flügelmutter (2 Stück)	handwheel (2 pieces)
365	4950 307	Kabelschelle (2 Stück)	cable clip ( 2 pieces)
369	4950 308	Knickschutz	antikink
401	4950 026	Griffoberteil mit Softschlauch	upper handlebar
402	4020 050	Schalter	switch
403	0012 625	Torx-Schraube (3 Stück)	screw (3 pieces)
404	4317 014	Schaltbügel	shackle
405	4935 105	Schelle	clamp
412	4940 105	Lager	bearing
413	0010 338	6kt.-Schraube	hexagon head cap screw
415	0015 820	Blech-Schraube	sheet metal screw
416	3585 100	Bügel, "Flick-Flack"	shackle, "Flick-Flack"
417	3585 503	Hutclips (2 Stück)	retainer (2 pieces)
418	4936 323	Zugentlastung	strain relief
466	6340 125	Verschlusskappe (2 Stück)	closing cap (2 pieces)
***	0054 331	Gebrauchsanweisung	operator manual

- Ⓓ 6.38 E 4950 080, Serie A, Abdeckhaube, Motor, Messer
- ⒼⒷ 6.38 E 4950 080, Series A, Motor covering, Motor, Blade

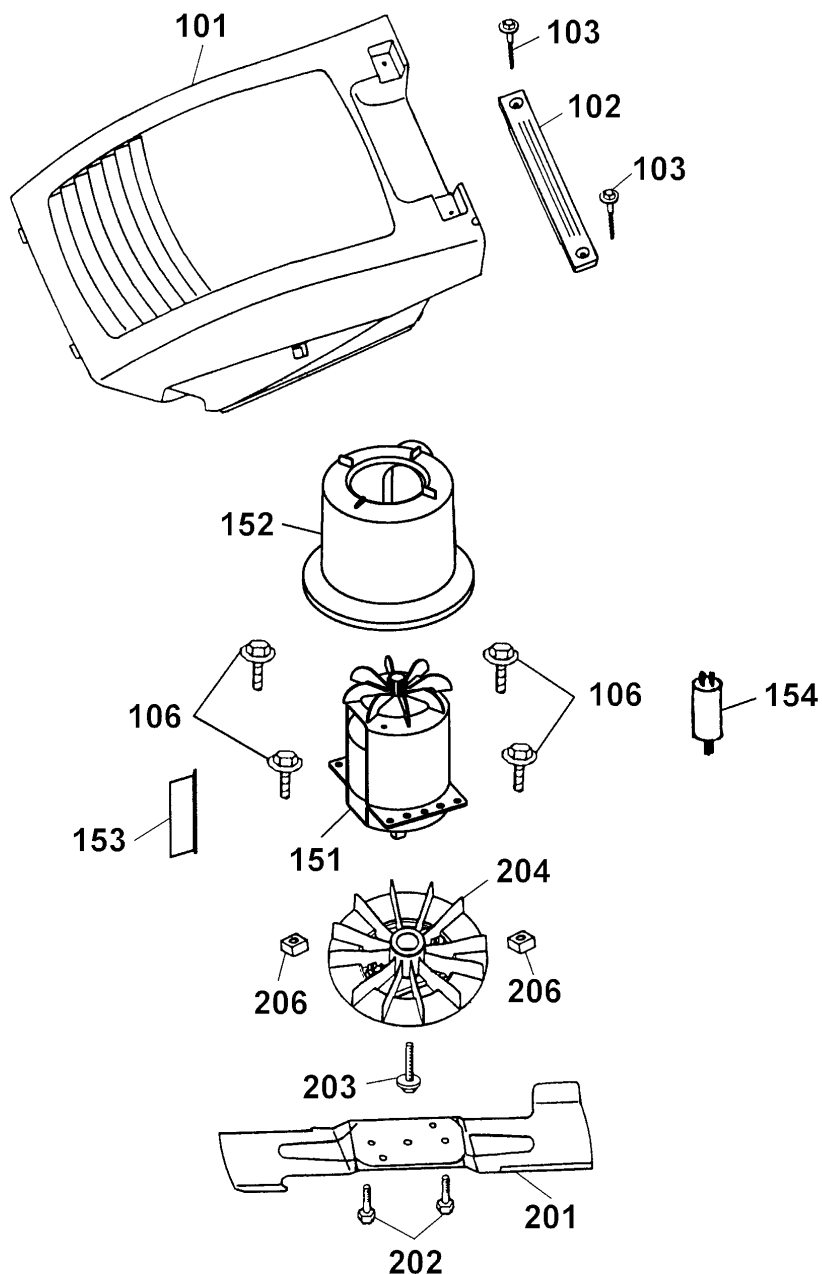



**6.38 E Abdeckhaube, Motor, Messer**  
**6.38 E Motor covering, Motor, Blade**

<b>Bild-Nr. / Ref. No.</b>	<b>Best.-Nr. / Part No.</b>	<b>Bezeichnung</b>	<b>Description</b>
101	4961 301	Abdeckhaube	motor covering
102	4961 303	Griff	handle
103	0012 639	Schraube K60x30 (2 St.)	screw K60x30 (2 pieces)
106	0012 618	SF-Schraube (4 Stück)	screw (4 pieces)
151	1141 080	Motor kpl. mit Kondensator	motor compl. with condenser
152	4961 326	Luftführungshaube	air conduction
153	1141 300	Luftleitfolie	foil
154	1133 030	Kondensator, 20 µF	condenser, 20 µF
201	4961 098	Messer VI 38 E	blade VI 38 E
202	0010 385	6kt.-Schraube (2 St.)	hex. screw (2 pieces)
203	0010 403	6kt.-Schraube	hex. screw
204	4961 036	Lüfter	fan
206	0016 409	4kt.-Mutter (2 St.)	square nut (2 pieces)

Ⓓ Fangkorb komplett 4950 065

ⒼⒷ Grass box compl. 4950 065

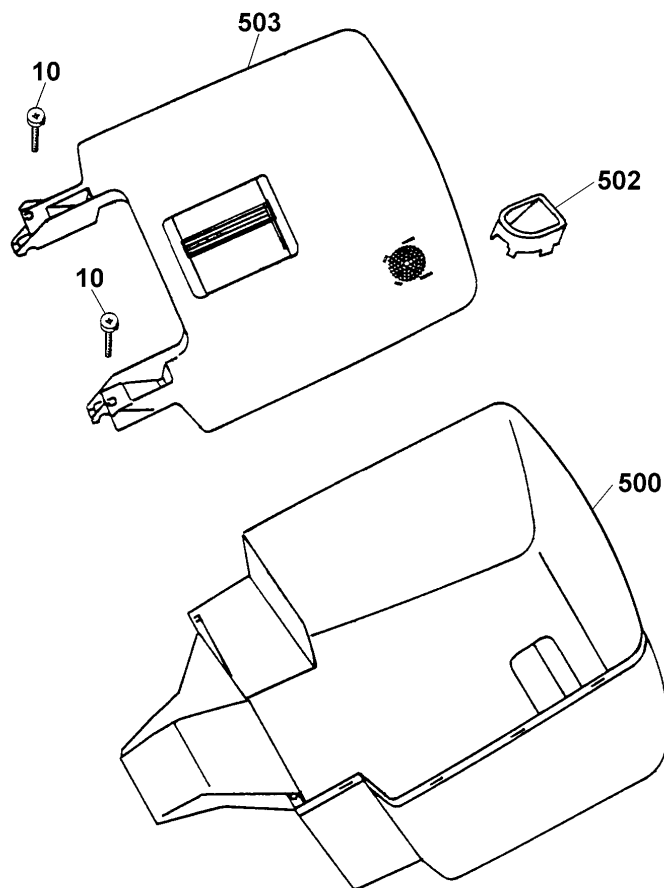

Bild-Nr. / Ref. No.	Best.-Nr. / Part No.	Bezeichnung	Description
10	0012 631	Schraube (2 Stück)	screw (2 pieces)
500	4961 311	Fangkorbunterteil	grass box under part
501	4936 061	Füllstandsanzeige	grass box fill indicator
503	4961 061	Fangkorboberteil	grass box upper part